

ChemPlant Technology s.r.o.

Report CPT-449-22

Date of issue: 23.2.2022

This report has 30 pages.



**Balancing and Data Reconciliation
of a Regenerative Air Preheater**

Author: Vit Madron

Ústí nad Labem

February 2022

ChemPlant Technology s.r.o.
V Zahradkach 656/31
400 01 Ústí nad Labem

Tel.: +420 474 527 221

E-mail: support@chemplant.cz

This report is the internal report of ChemPlant Technology, s.r.o. It is not allowed to pass this report to any third party without a written permission of ChemPlant Technology, s.r.o.

Index

SUMMARY	1
SYMBOLS AND ABBREVIATIONS	2
1. INTRODUCTION	3
2. BASIC TERMS	4
3. PLACE OF RAPH IN THE STEAM GENERATOR SYSTEM	6
4. BISECTOR RAPH	8
4.1. Mass balance only	8
4.2. Mass and heat balance	10
4.3. RAPH KPIs	11
4.4. Redundancy and Data Validation	12
4.5. Bisector RAPH summary	13
5. TRISECTOR RAPH	14
5.1. Introductory considerations	14
5.2. Mass and heat balance	14
5.3. X-Ratio and other indices of Trisector RAPH	16
5.4. Trisector RAPH summary	17
6. MODELING RAPH IN RECON	18
6.1. Mean Heat Capacities	18
6.2. Ash in Flue Gas	18
6.3. Composition the Flue Gas	19
7. DISCUSSION AND CONCLUSIONS	20
LITERATURE	21
APPENDIX 1: DVR VOCABULARY	22
APPENDIX 2: TRISECTOR RAPH EXAMPLE INPUT DATA	24

Summary

1. This report describes modeling and data reconciliation and validation of a regenerative air preheater (RAPH). The model is based on detailed mass, component and energy balance of RAPH
2. Bisector and Trisector RAPHs are analyzed in the sense of ASME PTC 4.3
3. The following issues are treated:
 - Setting up mass and energy balance model
 - Analyzing degrees of freedom and redundancy of measurements
 - Uncertainty of calculated results
 - Propagation of measurement errors
 - Data Validation - Possibility of detecting gross measurement errors
 - Implementation of a RAPH on line monitoring with the aid of program Recon.

Symbols and Abbreviations

DoR	Degree of Redundancy
DVR	Data Validation and Reconciliation
FG	Flue Gas
GE	Gross Error
M&HB	Mass and Heat Balance
PA	Primary Air
RAPH	Regenerative Air Preheater
SA	Secondary Air
SG	Steam Generator
UDE	User Defined Equation

1. Introduction

Air preheaters which preheat the combustion air by contact with hot flue gases are standard parts of modern steam generators. The average saving of fuel by using air preheat is estimated around at 10 %. The present report analyses problems connected with mass and energy balancing and Data Validation and Reconciliation (DVR) of regenerative types of air preheaters of rotating-plate type (Ljungstrom type, further denoted as RAPH). Such air preheaters are nowadays the most frequently used air preheaters in practice, especially in modern large capacity powerplants. Further on we will target on Bisector and Trisector RAPHs. Some findings can be applied also to other types of air preheaters.

While the mass and energy balancing of RAPH seems to be simple, the limited availability and accuracy of measurement around RAPH in practice may cause problems. The following issues are treated in next Chapters:

- Setting up mass and energy balance model
- Analyzing degrees of freedom and redundancy of measurements
- Uncertainty of calculated results
- Propagation of measurement errors I data processing
- Possibility of detecting possible gross measurement errors
- Implementation of a RAPH on line monitoring with the aid of program Recon.

This report is targeted at standard online monitoring and analysis in the power industry. We suppose no special procedures and instrumentation required by ad hoc testing or research (Performance Tests).

In this Report are quite frequently used terms from area of DVR. The Appendix 1 contains the short Vocabulary of basic DVR terms. This Vocabulary should serve only for re-brushing of the readers' previous knowledge in this area.

2. Basic terms

We will follow the nomenclature of [1]. The basic balancing flowsheet of a (bisector) RAPH is in the next Figure (T for temperatures, F for flowrates, indices are A for air, G for the flue gas, i for input and o for output):

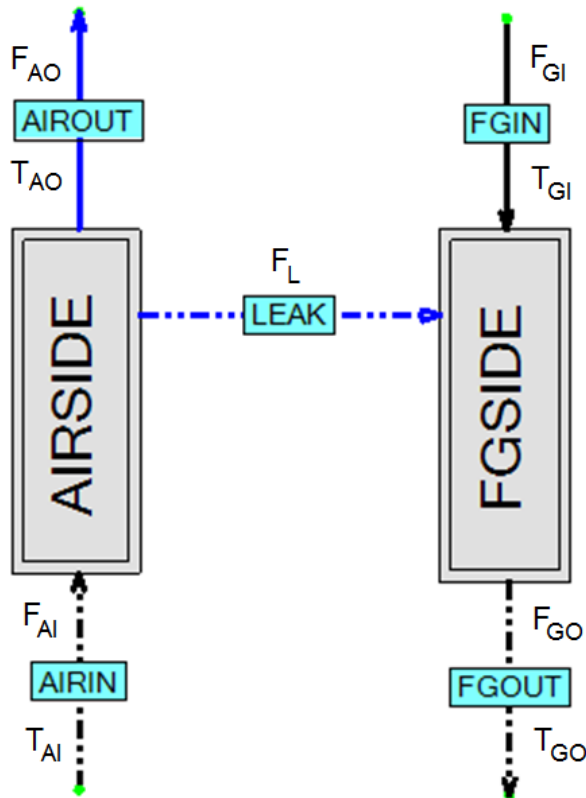

Fig. 2.1: The scheme for the mass and heat balance of a bisector RAPH

The balancing further on will mean the mass balance. Using other balancing units used in practice (volume) will be commented in the text.

The Leak F_L can be also expressed as the relative air leak A_L in %:

$$A_L = \frac{F_L}{F_{GI}} * 100 \% \quad (2-1)$$

Important is the hypothetical temperature T_{GONL} which is the **Gas Output temperature corrected for leaking air (No Leakage)**. The T_{GO} temperature is increased by the correction caused by cooling the flue gas by the cool air ingress.

$$T_{GONL} = T_{GO} + \frac{A_L c_{PA}(T_{GO}-T_{AI})}{100 c_{PG}} \quad (2-2)$$

where

c_{PA} = the mean specific heat of air between temperatures T_{AI} and T_{AO}

c_{PG} = the mean specific heat of flue gas between temperatures T_{GI} and T_{GONL}

Further variables used in the RAPH analysis are:

$$\text{Air Temperature Rise (ATR)} = T_{AO} - T_{AI} \quad (2-3)$$

$$\text{Gas Temperature Drop (GTD)} = T_{GI} - T_{GO} \quad (2-4)$$

$$\text{Temperature Head (TH)} = T_{GI} - T_{AI} \quad (2-5)$$

$$\begin{aligned} \text{Gas Side Efficiency} &= \text{GSE} = \text{GTD/TH} \\ &= (T_{GI} - T_{GONL}) / (T_{GI} - T_{AI}) \end{aligned} \quad (2-6)$$

$$\begin{aligned} \text{Air Side Efficiency} &= \text{ASE} = \text{ATR/TH} \\ &= (T_{AO} - T_{AI}) / (T_{GI} - T_{AI}) \end{aligned} \quad (2-7)$$

The last important characteristic of RAPH is the **X-Ratio** which is the ratio of the heat capacity of the air to the heat capacity of the flue gas going through the RAPH.

$$\text{X-Ratio} = \frac{F_{AO} c_{PA}}{F_{GI} c_{PG}} \quad (2-8)$$

or

$$\text{X-Ratio} = \frac{T_{GI} - T_{GONL}}{T_{AO} - T_{AI}} \quad (2-9)$$

The derivation of (2-9) from (2-8) can be found in [2], Section 7.07.

The X-Ratio characterizes operating conditions of RAPH. It is the complex variable which is influenced mostly by

- Moisture in coal and air
- RAPH leakage
- Excess oxygen in the flue gas.

3. Place of RAPH in the steam generator system

It is not possible to analyze RAPH without respecting RAPH integration in the overall steam generator system. There are many possible configuration of air preheating. As an example can be used the system shown in the next Fig. 3.1:

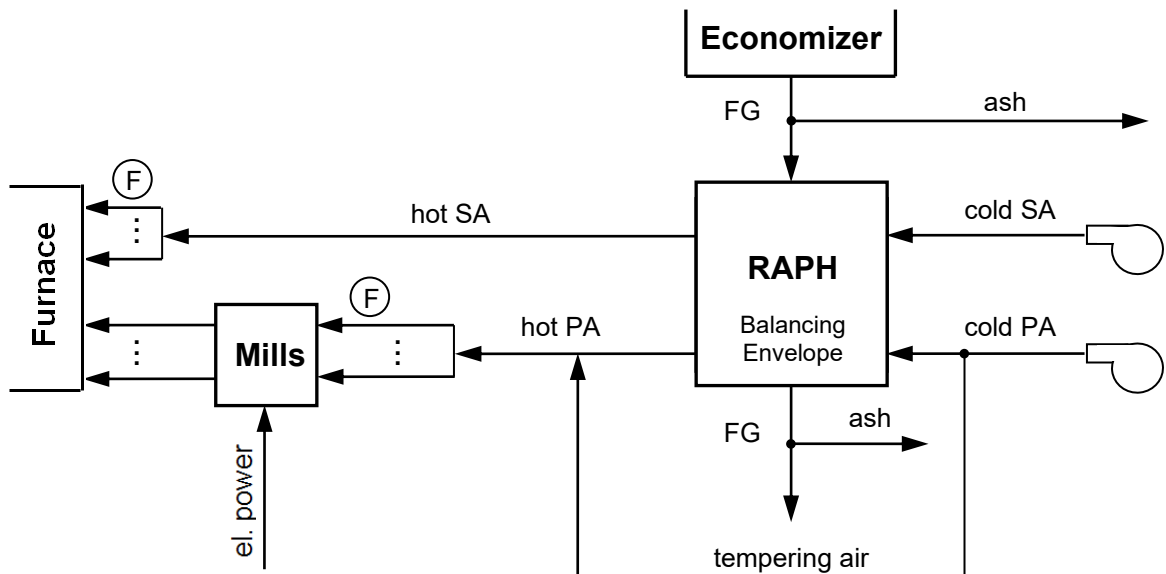

Fig. 3.1: Example of RAPH integration in the steam generator system

Such system can be found in modern large capacity boilers. RAPH inputs are the flue gas leaving the economizer after separation of a part of flying ash. The other inputs are the primary air (PA) and secondary air (SA) provided by fans. Part of the cold PA is used for the temperature control of PA before its entering the mill or the coal drier.

For setting up the RAPH mass and heat balance we need also flowrates of FG and air around the RAPH. Direct measuring of air and FG flowrates in large ducts on the RAPH balancing envelope is difficult (domain of specially designed test and research) and in practice it is not available. More easy is the measurement of air flowrates in front of burners and coal mills.

The typical availability of input data for the complete mass and heat balance is as follows:

- For FG the flowrate and composition can be available from the mass and component balance of the fuel burning. At the RAPH balancing envelope is usually available on-line measurement of O₂ and sometimes also the concentration of other components (CO₂, CO, ...). Depending on the type of analyzers there is usually needed some recalculation of measured concentrations (mass, volume, wet, dry states).
- The complete information about the air flow around the balancing envelope can be obtained from the mass and heat balance of the PA and SA system. The dry air composition is supposed to be constant (fixed). The ambient air humidity (moisture) should be measured.

- A special problem is that more than half of the overall flying ash goes through the RAPH. Ash flowrate is usually not measured online, it can be calculated from the coal ash content on the basis of some ash withdrawal static model (% of ash separated at individual places).

To summarize this Chapter: To make the analysis of RAPH data processing more tractable and generic, in the next Chapter 4 is presented the model which suppose knowledge (“measurement”) of some flows at the RAPH balancing envelope. This is not common in practice but it can be achieved by balancing of the whole SG system (boiler, RAPH, fans, mills, ...).

4. Bisector RAPH

A Bisector RAPH serves for preheating one air stream (PA or SA) by the contact with FG. As was described in the previous Chapter 3, the M&HB of the RAPH proper must be based on inputs and outputs of the model comprising the whole SG system – the SG proper, RAPH, coal driers and coal mills (see the final part of Chapter 3).

4.1. Mass balance only

The mass balance alone is capable of calculating the AIRLEAK stream flowrate

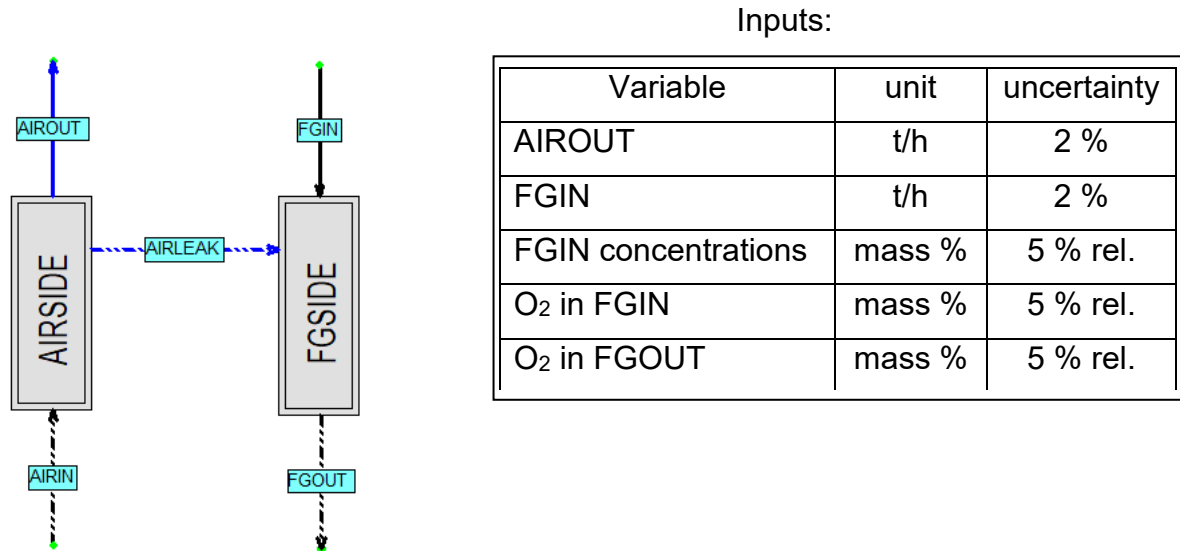

Fig. 4.1: Bisector RAPH flowsheet for the mass balance

The global information about model generated according to flowsheet in Fig. 4.1 are:

Number of nodes	2
Number of streams	5
Number of components	6
Number of measured variables	8
Number of adjusted variables	0
Number of non-measured variables	9
Number of observed variables	9
Number of non-observed variables	0
Number of equations	9
Number of independent equations	9
Number of user-defined equations	0
Degree of redundancy	0

Below are selected main results:

M A S S F L O W R A T E S (Summary)

Name	Type	Inp.value	Rec.value	Abs.error	
AIRIN	NO	1056.000	1121.035	28.554	T/H
AIRLEAK	NO	100.000	65.035	19.216	T/H
AIROUT	MN	1056.000	1056.000	21.120	T/H
FGIN	MN	1196.000	1196.000	23.920	T/H
FGOUT	NO	1200.000	1261.035	31.681	T/H

It is clear that this model has zero redundancy. It just calculates unmeasured variables from the model.

Let's notice the calculated AIRLEAK stream. The Absolute error (uncertainty) is 19.216 t/h which is 29.4 % of the calculated value 65.035 t/h. The relative uncertainty

of AIRLEAK is thus quite high. We can now try to find the reason for this shortage. Below is the analysis of errors propagation:

```
REPORT ABOUT PROPAGATION OF ERRORS
=====
```

```
Type Variable      Description
-----
MF  AIRLEAK        air leak
```

THE VARIANCE OF GIVEN VARIABLE IS CAUSED MAINLY BY:

```
Type Measured variable      Share
-----
C   O2<FGIN>                  35 % oxygen
C   O2<FGOUT>                 64 % oxygen
```

This short report says that the variance of calculated AIRLEAK flow is caused by 35 % by the measurement of O₂ concentration in the FGIN stream and by 64 % by the measurement of O₂ concentration in the FGOUT stream. Let's now decrease the uncertainty of O₂ measurement from 5 rel.% to 2 rel.% (see Fig. 4.1). The uncertainty of calculated AIRLEAK is now 7.778 t/h which represents 12.0 %. The report about errors propagation is below:

```
REPORT ABOUT PROPAGATION OF ERRORS
=====
```

```
Type Variable      Description
-----
MF  AIRLEAK        air leak
```

THE VARIANCE OF GIVEN VARIABLE IS CAUSED MAINLY BY:

```
Type Measured variable      Share
-----
C   O2<FGIN>                  34 % oxygen
C   O2<FGOUT>                 63 % oxygen
MF  FGIN                      3 % flue gas input
```

Measurement of oxygen concentrations in FG are still the bottleneck of AIRLEAK's uncertainty. But in practice it is difficult to attain better uncertainty than 2 % relative (ca 0.08 % absolute).

4.2. Mass and heat balance

The flowsheet with input data is presented in Fig. 4.2 (compare with Fig 4.1).

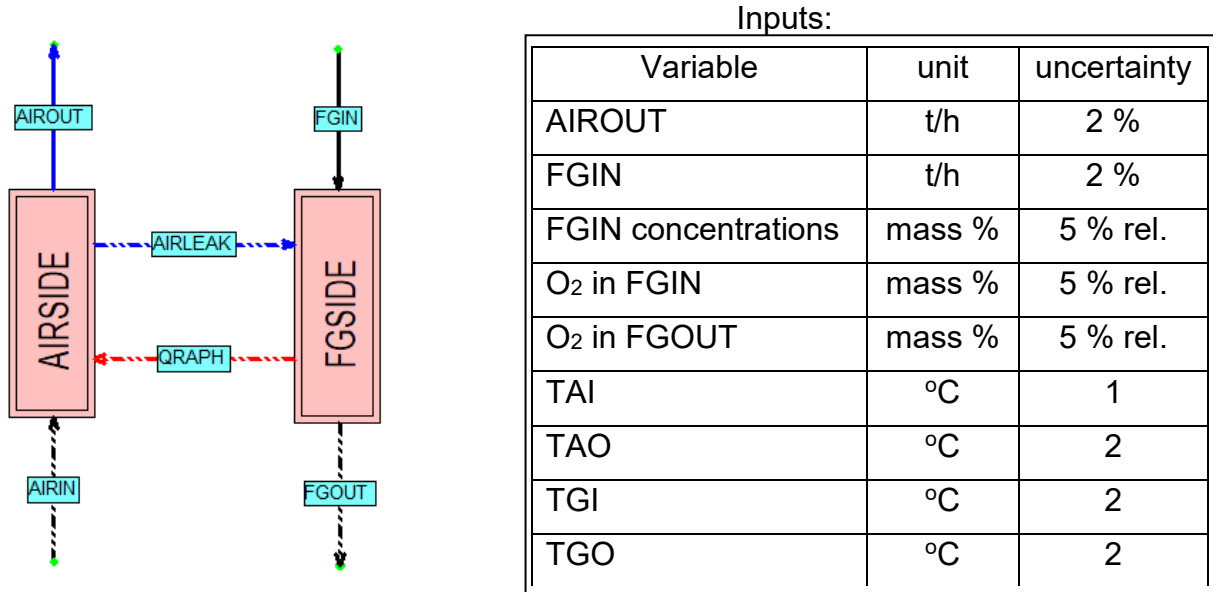

Fig. 4.2: Flowsheet and input data for RAPH

There remains to solve the question: “What is the temperature of AIRLEAK stream?”. The most straightforward is to use the arithmetic average of temperatures TAI and TAO. This can be in Recon arranged via User Defined Equation (UDE). With this assumption the global info about this model is:

GLOBAL DATA

Number of nodes	2
Number of heat nodes	2
Number of streams	6
Number of energy streams	1
Number of components	6
Number of temperatures	5
Number of measured variables	12
Number of adjusted variables	12
Number of non-measured variables	11
Number of observed variables	11
Number of non-observed variables	0
Number of free variables	0
Number of equations (incl. UDE)	12
Number of independent equations	12
Number of user-defined equations (UDE)	1
Degree of redundancy	1

In this case there is one Degree of Redundancy (two heat balance equations were added but there is also one new unknown variable – the QRAPH heat stream). All measured variables are adjusted which means that they are redundant. This means that in the case of a failure of one instrument the value can be calculated from other measured variables.

E N E R G Y S T R E A M S

Name	Type	Inp.value	Rec.value	Abs.error
QRAPH	NO	84.049	83.779	1.427 MW RAPH heat flux

The Absolute error (uncertainty) of QRAPH is 1.427 MW which represents 1.7 % of the Reconciled value 83.779 MW. This low uncertainty can be useful in further using of this result (calculation of the RAPH heat transfer coefficient).

There was one issue in the previous mass balance model in Section 4.1 – the precision of the AIRLEAK flowrate. In the mass and heat balance model the uncertainty of the AIRLEAK flowrate is 17.845 t/h, compare with 19.216 t/h in the only mass balance case. There is some improvement but not very substantial.

There is one DoR which can serve for calculating one unmeasured variable. There is one exception – the AIRLEAK temperature. This temperature can't be calculated from other measured variables. It must be set independently on the classical balancing – we have used the averaging of TAI and TAO which looks reasonable.

4.3. RAPH KPIs

In this section we will treat determination of two RAPH Key Performance Indicators – the X-ratio and the Heat Transfer Coefficient (HTC).

The X-Ratio was defined in Chapter 2. It requires the knowledge of the mean heat capacities of Air and FG in their temperature span. The result is

A U X I L I A R I E S

Name	Type	Inp.value	Rec.value	Abs.error
X-RATIO	NO	0,822	0,822	0,012 X-Ratio [1]

The relative uncertainty is 1.5 %.The key measured variables which influence X-Ratio's uncertainty are

REPORT ABOUT PROPAGATION OF ERRORS

Type	Variable	Description
V	X-RATIO	X-Ratio [%]

THE VARIANCE OF GIVEN VARIABLE IS CAUSED MAINLY BY:

Type	Measured variable	Share
C	O2<FGIN>	4 % oxygen
C	O2<FGOUT>	5 % oxygen
MF	AIROUT	13 % air output
MF	FGIN	12 % flue gas input
T	TAI	4 % air input
T	TAO	15 % air output
T	TGI	22 % flue gas input
T	TGO	25 % flue gas output

It can be seen that there is no dominant variable influencing the X-Ratio's uncertainty.

HTC definition requires some comment. The classical definition of HTC for the countercurrent heat exchanger is

$$Q = HTC * A * LMTD \quad (4-1)$$

where

Q is the Heat flux

A the heat transfer area

LMTD the logarithmic mean temperature difference.

In the case of RAPH is difficult to define the heat transfer area. In such case is possible to merge the product $HTC * A$ into one parameter, the so called *Overall HTC*.

$$Q = OHTC * LMTD \quad (4-2)$$

The unit of *OHTC* is MW/K in our system of units. The result is

A U X I L I A R I E S

Name	Type	Inp.value	Rec.value	Abs.error	
OHTC coefficient [MW/K]	NO	1,000	1,285	0,046	Heat transfer

The relative uncertainty of OHTC is 3.6 %. The key measured variables which influence X- Ratio's uncertainty are

REPORT ABOUT PROPAGATION OF ERRORS

=====

Type	Variable	Description
V	HTC	Heat transfer coefficient [MW/K]

THE VARIANCE OF GIVEN VARIABLE IS CAUSED MAINLY BY:

Type	Measured variable	Share
MF	AIROUT	3 %
MF	FGIN	14 % flue gas input
T	TAO	38 % air output
T	TGI	14 % flue gas input
T	TGO	26 % flue gas output

The HTC uncertainty is mainly influenced by measurement of temperatures.

4.4. Redundancy and Data Validation

Redundancy is Global and Local (see Appendix 1). In the case of M&HB the model Global Redundancy represented by DoR = 1 (not high). The Local Redundancy is measured by measured values Adjustability. Adjustability also influences Detectability of Gross Errors. Below is the info about selected measured redundant variables:

R E D U N D A N T M E A S U R E M E N T S

Type	Variable	Value	Adjustability	Threshold value			Unit
				Beta: 90%	Beta: 95%	Beta: 99%	
C	O2<FGIN>	3.50	0.005497	2.756	3.065	3.644	%
C	O2<FGOUT>	4.50	0.008630	2.516	2.798	3.327	%
MF	AIROUT	1046	0.211381	56.636	62.984	74.897	T/H
MF	FGIN	1206	0.202881	65.320	72.641	86.380	T/H
T	TAI	30	0.006894	14.067	15.644	18.603	C
T	TAO	301	0.026959	14.299	15.901	18.909	C
T	TGI	346	0.040695	11.679	12.988	15.444	C
T	TGO	120	0.039548	11.843	13.171	15.662	C

In the table which is generated by Recon (menu *Run/Classification*) we see *Threshold Values* for probabilities Beta 90, 95 and 99 %. The interpretation of this table for selected measured variables is as follows:

For the **O₂ concentration in the FGIN stream** (measured value = 3.50 %) the gross error must be at least 2.756 to be detected with probability 90 % or 3.065 to be detected with probability 95 %.

For the **AIROUT stream flowrate** (measured value = 1046 t/h) the gross error must be at least 56.636 to be detected with probability 90 % (5.4 % of the measured value).

For the **temperature TAO** (measured value = 301 °C) the gross error must be at least 14.299 °C to be detected with probability 90 %.

It can be seen that Threshold Values are quite high. Especially for the oxygen concentration the gross errors detection is practically useless. This is due to low redundancy of this model and supposed precision of measured variables.

4.5. Bisector RAPH summary

In literature about the Bisector RAPHs, including [1], the solution is frequently based on many approximations enabling one to do calculations “by hand”. The solution presented in this report uses the rigorous modeling by Recon.

The mass balance makes possible to calculate the leak flowrate. With the measured temperatures can be calculated basic RAPH characteristics (indices) like efficiencies and X-Ratio. With mass balance only the model is without redundancy (DoR = 0) and it is not possible to check data quality. The redundancy could be gained by including measuring concentrations of other components like CO₂.

M&HB completes the information by calculating the RAPH heat power. In this case the DoR = 1 and some data validation can be done. The uncertainty of the calculated leak is improved a little bit but it still remains high.

In general, the redundancy is not high, DoR = 0 for the mass balance model and DoR = 1 for the M&HB model. To lower the uncertainty of results the measurements of O₂ should be carried out with the highest precision as possible (frequent checking and calibration of analyzers). The other possibility is to include measurement of other components like CO₂.

5. Trisector RAPH

5.1. Introductory considerations

The Trisector RAPH preheats in one equipment both Primary and Secondary Air.

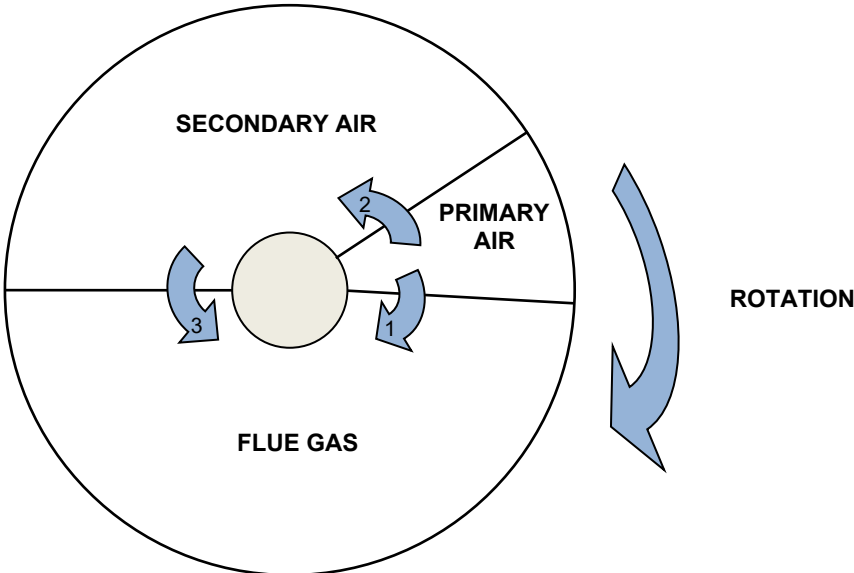

Fig. 5.1: Function of a trisector RAPH.

In ASME PTC 4.3 [1] is treated the Bisector RAPH only. The method described there can't be used for trisector RAPHs without some modifications. This concerns the mass and heat balance and also RAPHs' X-Ratio.

5.2. Mass and heat balance

The balancing flowsheet of the Trisector RAPH is shown in Fig. 5.2:

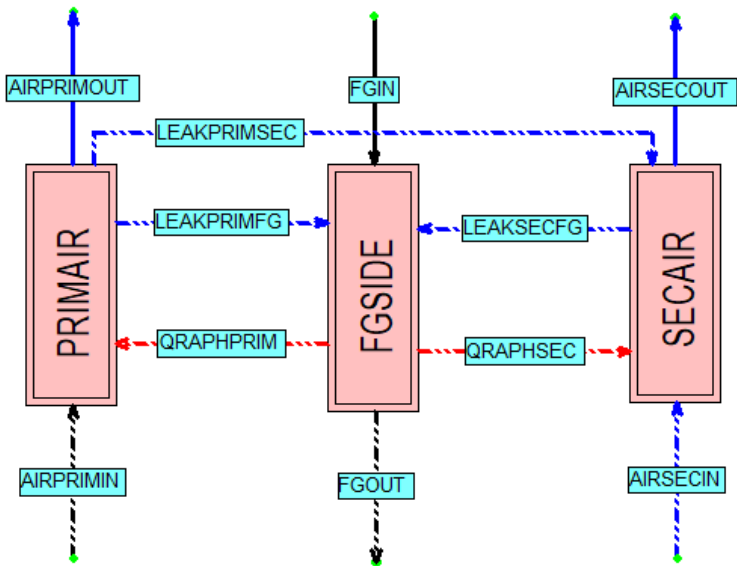

Fig. 5.2: Balancing schema of a Trisector RAPH

In comparison with the Bisector RAPH the balancing schema contains two air nodes, two heat fluxes and 3 leaks. Input and output temperatures of air streams are different. As in the case of the Bisector RAPH we will suppose that the temperature of air leaks is the arithmetic average of input and output air temperatures.

One significant problem of Trisector RAPH is the determination of flowrates of leaks. It is not possible to calculate them from the mass and heat balance only (they are unobservable). There are at least 2 possibilities how to solve this issue:

- (1) To complete the information about ratios of leaks taken over from the RAPH design data. It is sufficient to fix 2 ratios, for example ratios of PA leak and SA leak to the sum of all 3 leaks. This solution can be configured via 2 User Defined Equations.
- (2) The calculation of leaks can be based on pressures in PA, SA and FG spaces of RAPH if they are measured. There holds the approximate equation for leaks in the form

$$\text{Leak} = C (\Delta p)^{1/2} \quad (5-1)$$

where C is the coefficient depending mostly on the open area between individual RAPH spaces (depending on the state of RAPH seals) and also on physical properties (density, viscosity) of air. If we suppose that the coefficient C is the same for all leaks, we have 3 equations for leaks and one unknown coefficient. We have than 2 independent relations and the number of degrees of freedom is the same as in the method (1) above.

It is clear that in modeling leaks we use several assumptions which can be disputable. Quite reliable is the calculated **sum of leaks** PA → FG and SA → FG which is based on measurement of oxygen in both FG streams. In the example below is used the model (1) based on leaks' ratios taken over from the Design.

In the table below is the basic information about inputs' uncertainties (maximum measurement errors) used in the Example:

Table 5.1: Uncertainties of measured variables

Variable	unit	uncertainty
AIRPRIMOUT, AIRSECOUT	t/h	2 %
FGIN	t/h	2 %
FGIN concentrations	mass %	5 % rel.
O ₂ in FGIN	mass %	5 % rel.
O ₂ in FGOUT	mass %	5 % rel.
PRIMAIRIN, SECAIRIN	°C	1
PRIMAROUT, SECAROUT	°C	2
FGIN	°C	2
FGOUT	°C	2

Below are global data about the Trisector RAPH M&HB model:

GLOBAL DATA

Number of nodes	3
Number of heat nodes	3
Number of streams	11
Number of energy streams	2
Number of components	6
Number of temperatures	8
Number of auxiliaries	2
Number of measured variables	15
Number of adjusted variables	15
Number of non-measured variables	16
Number of observed variables	16
Number of non-observed variables	0
Number of free variables	0
Number of equations (incl. UDE)	17
Number of independent equations	17
Number of user-defined equations (UDE)	4
Degree of redundancy	1

Further selected results are

M A S S F L O W R A T E S (Summary)

Name	Type	Inp.value	Rec.value	Abs.error		
AIRPRIMIN	NO	370.881	370.883	19.384	T/H	PA input
AIRPRIMOUT	MC	308.000	308.152	6.127	T/H	PA output
AIRSECIN	NO	766.183	766.183	14.827	T/H	SA input
AIRSECOUT	MC	760.000	760.893	14.727	T/H	SA output
FGIN	MC	1255.000	1241.746	28.739	T/H	flue gas input
FGOUT	NO	1309.757	1309.768	39.328	T/H	FG output
LEAKPRIMFG	NO	55.172	55.174	16.148	T/H	PA leak to FG
LEAKPRIMSEC	NO	7.558	7.558	2.212	T/H	leak PA to SA
LEAKSECFG	NO	12.848	12.849	3.760	T/H	SA leak to FG

It can be seen again that calculated leaks' flowrates has high relative uncertainty, for example the leak LEAKPRIMFG (PA → FG) has calculated value 55.172 t/h and the uncertainty 16.148 t/h (29.3 %). The situation is similar like in the case of the Bisector RAPH, even worse.

E N E R G Y S T R E A M S

Name	Type	Inp.value	Rec.value	Abs.error		
QRAPHPRIM	NO	26.418	26.418	0.925	MW	PA RAPH heat flow
QRAPHSEC	NO	57.436	57.436	1.333	MW	SA RAPH heat flow

Again, as in the case of the Bisector RAPH, the relative uncertainty of calculated heat fluxes are acceptable, in the order of few %.

5.3. X-Ratio and other indices of Trisector RAPH

In the ASME PTC code 4.3 [1] is treated only the Bisector RAPH. The calculation of RAPH efficiencies and other indices according the [1] methodology must be modified

to respect the Trisector RAPH character. There are two air streams with different temperatures

Procedures for calculating important RAPH's KPIs (Flue Gas efficiency, X-Ratio, etc.) are tailored for the bisector RAPH. Mostly parameters of a single air stream must be replaced by a suitable value characterizing two streams (primary and secondary air. There can't be two FG efficiencies or two X-ratios for PA and SA. In the next table is described possible solution of this issue:

Bisector RAPH	Trisector RAPH
Air input temperature	Weighted average air input temperatures
Air output temperature	Weighted average air output temperatures
Air input flowrate	Sum of primary and secondary air input flowrates
Air output flowrate	Sum of primary and secondary air output flowrates

Weight means proportion of primary and secondary air flowrates in their summed flowrate.

5.4. *Trisector RAPH summary*

Trisector RAPH modeling is more complicated than that of Bisector RAPH and probably it can't be done "by hand". Precision (uncertainty) of results is similar like in the case of Bisector RAPHs. The relative precision of calculated leaks is not high and depends mostly on precision of FG O₂ concentrations measured at the RAPH input and output. The precision of calculated heat fluxes is relatively good.

The calculation of RAPH indices in the sense of ASME PTC 4.3 is not straightforward and the ASME PTC 4.3 procedures must be modified to respect the Trisector RAPH character.

6. Modeling RAPH in Recon

There are several things which deserve mentioning here.

6.1. Mean Heat Capacities

Calculations according to [1] require the knowledge of mean heat capacities c_p of gaseous streams in some temperature range. These variables can be seen in Recon for example in tables of heat balance, the right column.

Node: AIRSIDE								Raw data		Reconciled data	
Description: air side of RAPH								Component balance			
Inlet	MF [T/H]	HF [MW]	T [C]	P [KPA]	X [%]	H [J/KG]	CP [J/KG/C]	Exit with			
AIRIN	1115	19.8	30.0			63941	1015				
QRAPH		84.0									
In sum	1115	104									
Outlet	MF [T/H]	HF [MW]	T [C]	P [KPA]	X [%]	H [J/KG]	CP [J/KG/C]				
AIRLEAK	65.6	3.69	165			202445	1033				
AIROUT	1056	101	301			344277	1059				
In sum	1122	105									
Total	MF [T/H]	HF [MW]	T [C]	P [KPA]	X [%]	H [J/KG]	CP [J/KG/C]				
Imbalance	6.20	0.818									
Imbalance	0.555%	0.785%									

Fig. 6.1: Heat balance table

Anyway, these values can't be used in calculations. Basic variable in Recon are directly enthalpies at some given temperature (in the case of air and flue gas), heat capacities are only secondary variables. In practice mean heat capacities in the temperature range $T_1 - T_2$ can be calculated from enthalpies via User Defined Equations:

$$\text{Mean heat capacity} = [H(T_2) - H(T_1)] / (T_2 - T_1) \quad (6-1)$$

where $H(T_x)$ are enthalpies.

6.2. Ash in Flue Gas

While the Ash is not directly mentioned in [1], it deserves a comment. In Recon it is not possible to include ash in the flue gas (which is supposed to behave as the ideal gas). Ash is therefore modelled as the stream parallel with FG (temperatures of FG and Ash are identical).

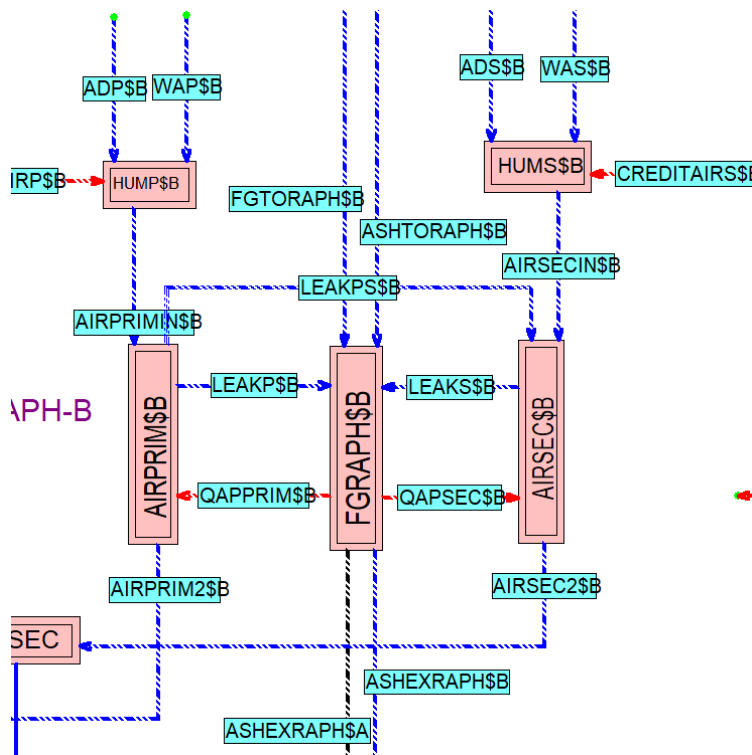

Fig. 6.2: Modeling Ash in Recon (see streams ASHTORAPH\$B and ASHEXRAPH\$B)

This practical solution was not used in this report to make it more simple. Luckily, heat capacities of FG and Ash are very similar.

6.3. Composition of the Flue Gas

The Boiler with its auxiliaries is usually modeled in mass units. In opposite of this the composition of flue gases is usually measured in volume (mole) units. Some concentrations can be measured in wet or in dry state. The recalculation of concentrations between these systems can be very tedious and prone to errors. For these reasons Recon is equipped by the possibility of automatic recalculation of concentrations between different concentrations systems. This is enabled by User Defined Equations (buttons *Component mol* and *Component mol/dry*). In this case the volume (mol) concentration is the Auxiliary variable which is recalculated into the concentrations in mass units. Example of such automatically generated UDE follows.

<input checked="" type="checkbox"/> Use in model?	
Equation	Description
O2FGEXRAPHWET\$A	O2 ex prim RAPH
Equation proper	
$[V<O2FGEXRAPHWET\$A>]/100-([C<FGEXRAPH\$A:O2>]/31.9988)/([C<FGEXRAPH\$A:O2>]/31.9988+[C<FGEXRAPH\$A:N2>]/28.0134+[C<FGEXRAPH\$A:AR>]/39.948+[C<FGEXRAPH\$A:CO2>]/44.00995+[C<FGEXRAPH\$A:SO2>]/64.0628+[C<FGEXRAPH\$A:H2OV>]/18.01534+[C<FGEXRAPH\$A:C.O>1/28.01055+0])$	

7. Discussion and conclusions

Regenerative air preheaters are frequent parts of industrial steam generators and their functioning significantly influences Heat Rate of the whole powerplant. The RAPH monitoring technology described in [1] was implemented by Recon with the following findings.

In literature about the Bisector RAPHs, including [1], the solution is frequently based on many approximations enabling one to do calculations "by hand". The solution presented in this report uses the rigorous modeling by Recon.

For the Bisector RAPH the mass balance makes possible to calculate the leak flowrate. With the measured temperatures can be calculated basic RAPH characteristics (indices) like the Leak, Air and FG efficiencies and X-Ratio. With mass balance the model is without redundancy ($DoR = 0$) and it is not possible to check data quality. The redundancy could be gained by including measuring concentrations of other components like CO_2 .

M&HB completes the information by calculating the RAPH heat power. In this case the $DoR = 1$ and some data validation can be done. The uncertainty of the calculated leak is improved a little bit but it still remains high.

In general, the redundancy is not high, $DoR = 0$ for the mass balance model and $DoR = 1$ for the M&HB model. To lower the uncertainty of results the measurements of O_2 should be carried out with the highest precision as possible (frequent checking and calibration of analyzers). The other possibility is to include measurement of other components like CO_2 .

Trisector RAPH modeling is more complicated than that of Bisector RAPH and probably it can't be done "by hand". Precision (uncertainty) of results is similar like in the case of Bisector RAPHs. The relative precision of calculated leaks is not high and depends mostly on precision of FG O_2 concentrations measured at the RAPH input and output. The precision of calculated heat fluxes is relatively good.

The calculation of the Trisector RAPH indices in the sense of ASME PTC 4.3 [1] is not straightforward and the ASME PTC 4.3 procedures must be modified to respect the Trisector RAPH character.

Literature

- [1] ASME PTC 4.3: Air Heaters, Reaffirmed 1991
- [2] Process data validation in practice. Applications from chemical, oil, mineral and power industries. Report CPT 229-07. Usti nad Labem 2007. Available via [Papers and reports | ChemPlant Technology - process data information systems, mass and energy balancing software](#)
- [3] Madron, F.: *Process Plant Performance. Measurement and Data Processing for Optimization and Retrofits*. Ellis Horwood, N.Y. 1992. Available via [Home Feed | ResearchGate](#)
- [4] Balancing and Data Reconciliation of a coal fired boiler. Report CPT 321-13. Usti nad Labem 2013

Appendix 1: DVR vocabulary

Data Validation and Reconciliation means the overall improvement of data quality (precision, completeness, reliability, ...). Here is very brief explanation of the most frequent notions in this area. Details can be found specialized texts like [2,3] which are freely available via Internet.

Adjustability – is the measure of **Local Redundancy**. It is defined as the decrease of uncertainty of a measured value due to DR.

$$\text{Adjustability} = (1 - \text{uncertainty of reconciled value} / \text{uncertainty of measured value})$$

Data Reconciliation – statistical adjustment of measured data to make them in agreement with the mathematical model (First Laws and other accepted concepts)

Data Validation – analysis of measured data set as concerns possible occurrence of Gross Errors (GE). GEs should be in the validation process **detected, identified and eliminated**

Degree of Redundancy (DoR) – most frequently the difference between the number of model equations and the number of unmeasured variables.

Global redundancy is defined by one number for the whole model – by the **Degree of redundancy**.

Gross Error – large measurement error which is greater than the accepted level of random errors

Gross Error Detectability – the probability of detecting a GE of some magnitude. See the **Threshold Value**.

Local redundancy – every measured variable has its **Adjustability**. Zero adjustability means nonredundant variable, value approaching 1 means strongly redundant variables which are tied with other measured variables.

Model – the system of mathematical equations valid for measured and unmeasured variables. Most frequently mass and energy (heat) balance, also thermodynamic equations.

Observability – the unmeasured variable is *observable* if it can be uniquely calculated from the model. The system is observable if all directly unmeasured variables are observable.

Propagation of errors – the method of analyzing which measured variables are the bottleneck of result's uncertainty. It is possible to find which measurements are critical and whose precision should be improved.

Redundancy – means that there are more measured data than the essential number of data needed for complete **Observability** of the system. There are two measures of Redundancy – the **Global** and **Local**

Redundant measurement – measured variable which, in the case that it is not measured, can be uniquely calculated from the model

Threshold value – the value of a gross error of some measured variable which will be detected with some specified probability (usually 90 or 95 %). See **Gross error Detectability**.

Uncertainty of a result – interval in which lies (with the 95 % probability) the true (unknown) value of the result. In Recon the uncertainty is expressed as the \pm *Maximum Error*.

Appendix 2: Trisector RAPH Example input data

RECON 11.9.7-Pro [ChemPlant Technology s.r.o.]
Task: TRISECTORHEAT (Bisector RAPH)

Balance: [20.01.2022 05:00; 20.01.2022 06:00)

G L O B A L D A T A

Heat balance calculations	No
Number of nodes	3
Number of heat nodes	3
Number of streams	11
Number of energy streams	2
Number of components	6
Number of temperatures	8
Number of auxiliaries	2

C O M P O N E N T S

ID	Description	Chemical name
O2	oxygen	Oxygen
N2	nitrogen	Nitrogen
AR	argon	Argon
CO2	carbon dioxide	Carbon dioxide
SO2	sulphur dioxide	Sulfur dioxide
V2OV	water vapor	Steam

N O D E S

ID	Description	Remark
ENVIRON	Environment	unbalanced
FGSIDE	flue gas side	
PRIMAIR	primary air side of RAPH	
SECAIR		

S T R E A M S

ID	From node	To node	Master stream	Description
AIRPRIMIN	ENVIRON	PRIMAIR		PA input
AIRPRIMOUT	PRIMAIR	ENVIRON	AIRPRIMIN	PA output
AIRSECIN	ENVIRON	SECAIR	AIRPRIMIN	SA input
AIRSECOUT	SECAIR	ENVIRON	AIRPRIMIN	SA output
FGIN	ENVIRON	FGSIDE		flue gas input
FGOUT	FGSIDE	ENVIRON		FG output
LEAKPRIMFG	PRIMAIR	FGSIDE	AIRPRIMIN	PA leak to FG
LEAKPRIMSEC	PRIMAIR	SECAIR	AIRPRIMIN	leak PA to SA
LEAKSECFCG	SECAIR	FGSIDE	AIRPRIMIN	SA leak to FG
QRAPHPRIM	FGSIDE	PRIMAIR		PA RAPH heat flow
QRAPHSEC	FGSIDE	SECAIR		SA RAPH heat flow

M A T E R I A L S T R E A M S

ID	Component	Type	Value	Max.error	
AIRPRIMIN	Flowrate	N	370.8811		T/H
	O2	F	22.890000		%wt
	N2	F	74.460000		%wt
	AR	F	1.260000		%wt
	CO2	F	5.00000E-2		%wt
	SO2	F	0.00000E+0		%wt
	V2OV	F	1.340000		%wt
AIRPRIMOUT	Flowrate	M	308.0000	2.0000%	T/H
	O2	F	22.890000		%wt

N2	F	74.460000	%wt
AR	F	1.260000	%wt
CO2	F	5.00000E-2	%wt
SO2	F	0.00000E+0	%wt
V2OV	F	1.340000	%wt

(Master stream = AIRPRIMIN)

AIRSECIN	Flowrate	N	766.1833	T/H
	O2	F	22.890000	%wt
	N2	F	74.460000	%wt
	AR	F	1.260000	%wt
	CO2	F	5.00000E-2	%wt
	SO2	F	0.00000E+0	%wt
	V2OV	F	1.340000	%wt

(Master stream = AIRPRIMIN)

AIRSECOUT	Flowrate	M	760.0000	2.0000%	T/H
	O2	F	22.890000		%wt
	N2	F	74.460000		%wt
	AR	F	1.260000		%wt
	CO2	F	5.00000E-2		%wt
	SO2	F	0.00000E+0		%wt
	V2OV	F	1.340000		%wt

(Master stream = AIRPRIMIN)

FGIN	Flowrate	M	1255.0000	5.0000%	T/H
	O2	M	3.500000	0.200000	%wt
	N2	N	67.663010		%wt
	AR	M	1.140000	5.00000E-2	%wt
	CO2	M	22.180000	0.500000	%wt
	SO2	M	0.140000	1.00000E-2	%wt
	V2OV	M	5.380000	2.00000E-2	%wt

FGOUT	Flowrate	N	1309.7566		T/H
	O2	M	4.500000	0.200000	%wt
	N2	N	68.016000		%wt
	AR	N	1.146283		%wt
	CO2	N	21.031090		%wt
	SO2	N	0.132731		%wt
	V2OV	N	5.170177		%wt

LEAKPRIMFG	Flowrate	N	55.1715		T/H
	O2	F	22.890000		%wt
	N2	F	74.460000		%wt
	AR	F	1.260000		%wt
	CO2	F	5.00000E-2		%wt
	SO2	F	0.00000E+0		%wt
	V2OV	F	1.340000		%wt

(Master stream = AIRPRIMIN)

LEAKPRIMSEC	Flowrate	N	7.5577		T/H
	O2	F	22.890000		%wt
	N2	F	74.460000		%wt
	AR	F	1.260000		%wt
	CO2	F	5.00000E-2		%wt
	SO2	F	0.00000E+0		%wt
	V2OV	F	1.340000		%wt

(Master stream = AIRPRIMIN)

LEAKSECFG	Flowrate	N	12.8482		T/H
	O2	F	22.890000		%wt
	N2	F	74.460000		%wt
	AR	F	1.260000		%wt
	CO2	F	5.00000E-2		%wt
	SO2	F	0.00000E+0		%wt

V2OV F 1.340000 %wt
 (Master stream = AIRPRIMIN)

E N E R G Y S T R E A M S [MW]

ID	Type	Value	Max.error
QGRAPHPRIM	N	26.4179	
QGRAPHSEC	N	57.4356	

T E M P E R A T U R E S [C]

ID	Type	Value	Max.error
FGIN	M	341.0000	3.0000
FGOUT	M	120.0000	2.0000
PRIMAIRIN	M	30.0000	2.0000
PRIMAIRLEAK	N	165.5120	
PRIMAIROUT	M	301.0000	3.0000
SECAIRIN	M	28.0000	2.0000
SECAIRLEAK	N	159.0296	
SECAIROUT	M	290.0000	3.0000

W E T N E S S E S [%]

ID	Type	Value	Max.error
steam	F	0.000E+0	
water	F	100.0000	

A U X I L I A R I E S

ID	Type	Value	Max.error
RATIOLEAKPFG	F	0.7300	1
RATIOLEAKSFG	F	0.1700	1

H E A T N O D E S

ID	Stream	Function	Temperature	Pressure	Wetness
FGSIDE	FGIN	IG(T)	FGIN		
	FGOUT	IG(T)	FGOUT		
	LEAKPRIMFG	IG(T)	PRIMAIRLEAK		
	LEAKSECFG	IG(T)	SECAIRLEAK		
PRIMAIR	AIRPRIMIN	IG(T)	PRIMAIRIN		
	AIRPRIMOUT	IG(T)	PRIMAIROUT		
	LEAKPRIMFG	IG(T)	PRIMAIRLEAK		
	LEAKPRIMSEC	IG(T)	PRIMAIRLEAK		
SECAIR	LEAKSECFG	IG(T)	SECAIRLEAK		
	AIRSECIN	IG(T)	SECAIRIN		
	AIRSECOUT	IG(T)	SECAIROUT		
	LEAKPRIMSEC	IG(T)	PRIMAIRLEAK		

U S E R E Q U A T I O N S

ID	Description Programmatic code	Remark
LEAKRATIOSFG	$\frac{[S<LEAKSECFG>]}{([S<LEAKPRIMFG>]+[S<LEAKSECFG>]+[S<LEAKPRIMSEC>])-[V<RATIOLEAKSFG>]}$	Model
LEAKRATIPFG	$\frac{[S<LEAKPRIMFG>]}{([S<LEAKPRIMFG>]+[S<LEAKSECFG>])}$	Model

$$+[S<LEAKPRIMSEC>] - [V<RATIOLEAKPFG>]$$

PRIMAIRLEAKTEMP air leak

$$[T<PRIMAIRLEAK>] - ([T<PRIMAIRIN>] + [T<PRIMAIROUT>]) / 2$$

Model

SECAIRLEAKTEMP

$$[T<SECAIRLEAK>] - ([T<SECAIRIN>] + [T<SECAIROUT>]) / 2$$

Model

Appendix 3: Trisector RAPH Example results

RECON 11.9.7-Pro [ChemPlant Technology s.r.o.]
Task: TRISECTORHEAT (Bisector RAPH)

Balance: [20.01.2022 05:00; 20.01.2022 06:00)

I T E R A T I O N S

Iter	Qeq	Qx	Qy	Qmin
START	1.1422E+05			
1	4.3088E+01	2.4632E-01	3.1820E+01	2.1676E-01
2	5.3971E-03	1.6843E-04	7.2980E+00	2.1705E-01
3	8.0208E-08	2.0665E-08	5.2790E-04	2.1705E-01

Legend:

Qeq mean residual of equations
Qx mean increment of measured variables in iteration
Qy mean increment of non-measured variables in iteration
Qmin least-square function

G L O B A L D A T A

Number of nodes	3
Number of heat nodes	3
Number of streams	11
Number of energy streams	2
Number of components	6
Number of temperatures	8
Number of auxiliaries	2
Number of measured variables	15
Number of adjusted variables	15
Number of non-measured variables	16
Number of observed variables	16
Number of non-observed variables	0
Number of free variables	0
Number of equations (incl. UDE)	17
Number of independent equations	17
Number of user-defined equations (UDE)	4
Degree of redundancy	1
Mean residue of equations	8.0208E-08
Qmin	2.1705E-01
Qcrit	3.8400E+00
Status (Qmin/Qcrit)	0.056524

M A S S F L O W R A T E S (Summary)

Name	Type	Inp.value	Rec.value	Abs.error		
AIRPRIMIN	NO	370.881	370.883	19.384	T/H	PA input
AIRPRIMOUT	MC	308.000	308.152	6.127	T/H	PA output
AIRSECIN	NO	766.183	766.183	14.827	T/H	SA input
AIRSECOUT	MC	760.000	760.893	14.727	T/H	SA output
FGIN	MC	1255.000	1241.746	28.739	T/H	flue gas input
FGOUT	NO	1309.757	1309.768	39.328	T/H	FG output
LEAKPRIMFG	NO	55.172	55.174	16.148	T/H	PA leak to FG
LEAKPRIMSEC	NO	7.558	7.558	2.212	T/H	leak PA to SA
LEAKSECFG	NO	12.848	12.849	3.760	T/H	SA leak to FG

F L O W R A T E S & C O N C E N T R A T I O N S

Stream: AIRPRIMIN (From node ENVIRON -> To node PRIMAIR)
M = 28.732 KG/KMOL

No.	Name	Type	Inp.value	Rec.value	Abs.error		
	Flowrate	NO	370.881	370.883	19.384	T/H	PA input
1	O2	F	22.890	22.890		%wt	Oxygen

2	N2	F	74.460	74.460	%wt	Nitrogen
3	AR	F	1.260	1.260	%wt	Argon
4	CO2	F	0.050	0.050	%wt	Carbon dioxide
6	V2OV	F	1.340	1.340	%wt	Steam

Stream: AIRPRIMOUT (From node PRIMAIR -> To node ENVIRON)
M = 28.732 KG/KMOL; Master stream = AIRPRIMIN

No.	Name	Type	Inp.value	Rec.value	Abs.error		
	Flowrate	MC	308.000	308.152	6.127	T/H	PA output
1	O2	F	22.890	22.890		%wt	Oxygen
2	N2	F	74.460	74.460		%wt	Nitrogen
3	AR	F	1.260	1.260		%wt	Argon
4	CO2	F	0.050	0.050		%wt	Carbon dioxide
6	V2OV	F	1.340	1.340		%wt	Steam

Stream: AIRSECIN (From node ENVIRON -> To node SECAIR)
M = 28.732 KG/KMOL; Master stream = AIRPRIMIN

No.	Name	Type	Inp.value	Rec.value	Abs.error		
	Flowrate	NO	766.183	766.183	14.827	T/H	SA input
1	O2	F	22.890	22.890		%wt	Oxygen
2	N2	F	74.460	74.460		%wt	Nitrogen
3	AR	F	1.260	1.260		%wt	Argon
4	CO2	F	0.050	0.050		%wt	Carbon dioxide
6	V2OV	F	1.340	1.340		%wt	Steam

Stream: AIRSECOUT (From node SECAIR -> To node ENVIRON)
M = 28.732 KG/KMOL; Master stream = AIRPRIMIN

No.	Name	Type	Inp.value	Rec.value	Abs.error		
	Flowrate	MC	760.000	760.893	14.727	T/H	SA output
1	O2	F	22.890	22.890		%wt	Oxygen
2	N2	F	74.460	74.460		%wt	Nitrogen
3	AR	F	1.260	1.260		%wt	Argon
4	CO2	F	0.050	0.050		%wt	Carbon dioxide
6	V2OV	F	1.340	1.340		%wt	Steam

Stream: FGIN (From node ENVIRON -> To node FGSIDE)
M = 29.78 KG/KMOL

No.	Name	Type	Inp.value	Rec.value	Abs.error		
	Flowrate	MC	1255.000	1241.746	28.739	T/H	flue gas input
1	O2	MC	3.500	3.497	0.199	%wt	Oxygen
2	N2	NO	67.663	67.663	0.541	%wt	Nitrogen
3	AR	MC	1.140	1.140	0.050	%wt	Argon
4	CO2	MC	22.180	22.180	0.500	%wt	Carbon dioxide
5	SO2	MC	0.140	0.140	1.0000E-2	%wt	Sulfur dioxide
6	V2OV	MC	5.380	5.380	0.020	%wt	Steam

Stream: FGOUT (From node FGSIDE -> To node ENVIRON)
M = 29.723 KG/KMOL

No.	Name	Type	Inp.value	Rec.value	Abs.error		
	Flowrate	NO	1309.757	1309.768	39.328	T/H	FG output
1	O2	MC	4.500	4.504	0.199	%wt	Oxygen
2	N2	NO	68.016	68.016	0.545	%wt	Nitrogen
3	AR	NO	1.146	1.146	0.047	%wt	Argon
4	CO2	NO	21.031	21.031	0.568	%wt	Carbon dioxide
5	SO2	NO	0.133	0.133	9.6849E-3	%wt	Sulfur dioxide
6	V2OV	NO	5.170	5.170	0.060	%wt	Steam

Stream: LEAKPRIMFG (From node PRIMAIR -> To node FGSIDE)
M = 28.732 KG/KMOL; Master stream = AIRPRIMIN

No.	Name	Type	Inp.value	Rec.value	Abs.error		
	Flowrate	NO	55.172	55.174	16.148	T/H	PA leak to FG
1	O2	F	22.890	22.890		%wt	Oxygen
2	N2	F	74.460	74.460		%wt	Nitrogen
3	AR	F	1.260	1.260		%wt	Argon
4	CO2	F	0.050	0.050		%wt	Carbon dioxide

6 V2OV F 1.340 1.340 %wt Steam

Stream: LEAKPRIMSEC (From node PRIMAIR -> To node SECAIR)
M = 28.732 KG/KMOL; Master stream = AIRPRIMIN

No.	Name	Type	Inp.value	Rec.value	Abs.error	
	Flowrate	NO	7.558	7.558	2.212	T/H leak PA to SA
1	O2	F	22.890	22.890		%wt Oxygen
2	N2	F	74.460	74.460		%wt Nitrogen
3	AR	F	1.260	1.260		%wt Argon
4	CO2	F	0.050	0.050		%wt Carbon dioxide
6	V2OV	F	1.340	1.340		%wt Steam

Stream: LEAKSECFG (From node SECAIR -> To node FGSIDE)
M = 28.732 KG/KMOL; Master stream = AIRPRIMIN

No.	Name	Type	Inp.value	Rec.value	Abs.error	
	Flowrate	NO	12.848	12.849	3.760	T/H SA leak to FG
1	O2	F	22.890	22.890		%wt Oxygen
2	N2	F	74.460	74.460		%wt Nitrogen
3	AR	F	1.260	1.260		%wt Argon
4	CO2	F	0.050	0.050		%wt Carbon dioxide
6	V2OV	F	1.340	1.340		%wt Steam

E N E R G Y S T R E A M S

Name	Type	Inp.value	Rec.value	Abs.error	
QRAPHPRIM	NO	26.418	26.418	0.925	MW PA RAPH heat flow
QRAPHSEC	NO	57.436	57.436	1.333	MW SA RAPH heat flow

T E M P E R A T U R E S

Name	Type	Inp.value	Rec.value	Abs.error	
FGIN	MC	341.000	340.819	2.903	C flue gas input
FGOUT	MC	120.000	120.079	1.972	C flue gas output
PRIMAIRIN	MC	30.000	29.979	1.998	C PA input
PRIMAIRLEAK	NO	165.512	165.510	1.802	C PA leak
PRIMAIROUT	MC	301.000	301.042	2.995	C PA output
SECAIRIN	MC	28.000	27.956	1.991	C SA input
SECAIRLEAK	NO	159.030	159.029	1.798	C SA leak
SECAIROUT	MC	290.000	290.103	2.968	C SA output

W E T N E S S E S

Name	Type	Inp.value	Rec.value	Abs.error	
steam	F	0.000	0.000		% saturated steam
water	F	100.000	100.000		% saturated water

A U X I L I A R I E S

Name	Type	Inp.value	Rec.value	Abs.error	
RATIOLEAKPFG	F	0.730	0.730		ratio leak PA to FG
RATIOLEAKSFG	F	0.170	0.170		ratio leak SA to FG

End of results

Calculations lasted 00:00:00.220
Report created 18.02.2022 18:00:50